

Duplex Fabricated Strainers

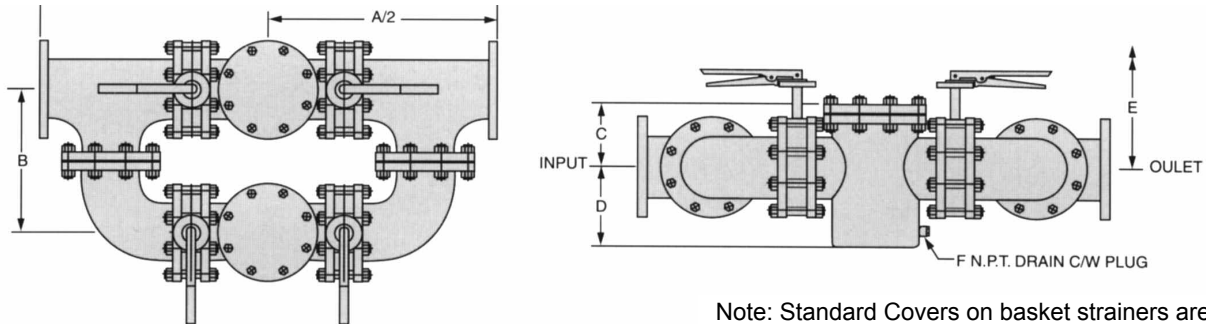

Note: Standard Covers on basket strainers are bolted.

SPECIFICATION:

The Duplex Strainer shall be designed and manufactured to meet ASME class 125 rated flanges. The duplex strainer shall have four butterfly isolation valves with stainless trim. The strainer body shall be cast iron material and shall be an angular basket design. The header shall be carbon steel material and shall have off-center inlet/outlet connections. The strainer shall be furnished with a bottom blowdown capability. The screen shall be size _____ perforated SS. The Duplex Strainer shall have an inlet size of _____ and Open Area Ratio of _____. The Duplex Strainer shall be American Wheatley Model DFS's _____

MATERIALS OF CONSTRUCTION

Basket Strainers:	Standard	Cast Iron 304 SS Basket
Headers:	Flanged Fittings	Carbon Steel
Shutoff Valves:	Standard	Butterfly Valves
		Ductile Iron Body (non wetted part)
		CF8M Disc EPDM seats
Hardware:	Stud	A193-B7
	Nut	A194-2H

Inlet/Outlet Connections*: 2"-16"
(RF or FF Flanged)
*Larger Sizes available upon request

SCREEN OPENINGS (Basket Strainers)		
2" - 3"	3/64" Perf.	304SS
4" - 16"	1/8" Perf.	304SS

Note: Other screen/mesh liners available upon request.

PART NUMBER	DIAMETER A (IN.)	LENGTH B (IN.)	LENGTH C (IN.)	LENGTH D (IN.)	LENGTH E (IN.)	F NPT	WEIGHT lbs.	
							COVER	UNIT
DFS-002	29 7/16"	9 1/8"	4 1/16"	5"	11 3/4"	1/2	5	174
DFS-003	35 7/16"	11 1/8"	5 1/16"	7 1/8"	15 3/8"	3/4	9	306
DFS-004	41 5/8"	13 1/8"	5 5/8"	8"	17 3/4"	1	13	499
DFS-006	51 1/4"	16 1/8"	6 3/4"	9"	23"	1	26	735
DFS-008	59 1/2"	18 1/8"	7 15/16"	12"	30"	1 1/2	45	1216
DFS-010	69 5/16"	22 1/8"	12"	14"	35 1/2"	1 1/2	70	1958
DFS-012	80 3/4"	24 1/8"	13 1/8"	17"	42 1/2"	2	110	2919
DFS-014	92 1/4"	28 1/8"	15 1/2"	22"	53"	1 1/2	140	4182
DFS-016	99 15/16"	30 1/8"	16 5/8"	22 7/8"	55 5/8"	2	180	5566

*Weights and dimensions with Bolted Cover.
Dimensions shown are subject to change. Contact factory for certified prints when required.

JOB NAME _____
 LOCATION _____

 CONTRACTOR _____
 CONTRACTOR P.O. NO. _____

ITEMS	QUANTITY
_____	_____
_____	_____
_____	_____
_____	_____
_____	_____



1005 E. Houston
 Broken Arrow, OK 74012
 Toll Free: 866-204-5229
 PH: 918-317-0401
 FAX: 918-317-0407
 www.wheatleyhvac.com
 e-mail: sales@globalflowproducts.com