

WBF Tank

Instructions for Bladder change

RECOMMENDED TOOLS AND SUPPLIES:

- | | |
|--------------------------|-------------------|
| 1. Plumbers tool box | 5. Pressure Gauge |
| 2. Compressed air source | 6. Length of rope |
| 3. Replacement Bladder | 7. Work light |
| 4. Chain block | 8. Extension cord |
- Isolate bladder type expansion tank from system. Shut off automatic fill, valve and drain boiler to release all system pressure.
 - Bleed system air charge through air charging valve. Remove air valve core at top of the tank and discharge remaining air.
 - Disconnect tank from the system.
 - Remove bolted bottom flange. Prior to removal, mark mating flanges in order to match up properly when reassembling.
 - Open and unhook the hanger from the top of the tank.
 - Using the chain block and a slight twisting motion, slide the bladder out of the tank.
 - Clean up any remaining water, dry out the inside of the tank and clean out any remaining dirt or foreign particles. Check the inside of the tank for any sharp edges that may cut the bladder.
 - Carefully roll up the replacement bladder lengthwise, with both sides rolled toward the middle like a scroll. This insures the bladder will expand without twisting when filled. Secure at intervals with rope or cord in order to keep it rolled.
 - Drop a rope through the top hanger opening and tie it to the bladder.
 - Insert the replacement bladder, removing the rope or cord as it nears the tank opening. Many times on larger sized tanks, the bladder may be inserted more easily with the tank laying on it's side on the floor.
 - By pulling on the rope, the bladder can be pulled up into position, replace the hanger hook and remove the rope.
 - Replace the bottom flange, align the marks and tighten the bolts evenly, using a star pattern.
 - Using compressed air source and pressure gauge, apply 10 psi air pressure to the flange connection then relive pressure. These actions should ensure proper positioning of the replacement bladder within the tank.
 - Reassemble the air valve at the top and seal the hanger opening.
 - Precharge tank to fill-pressure or minimum operating pressure.
 - Using soapy water, check the air valve, hanger plug and bottom flange joint for leakage.
 - Reconnect the system, open the fill-valve and check operation of the tank. Always precharge tank before completing this step.

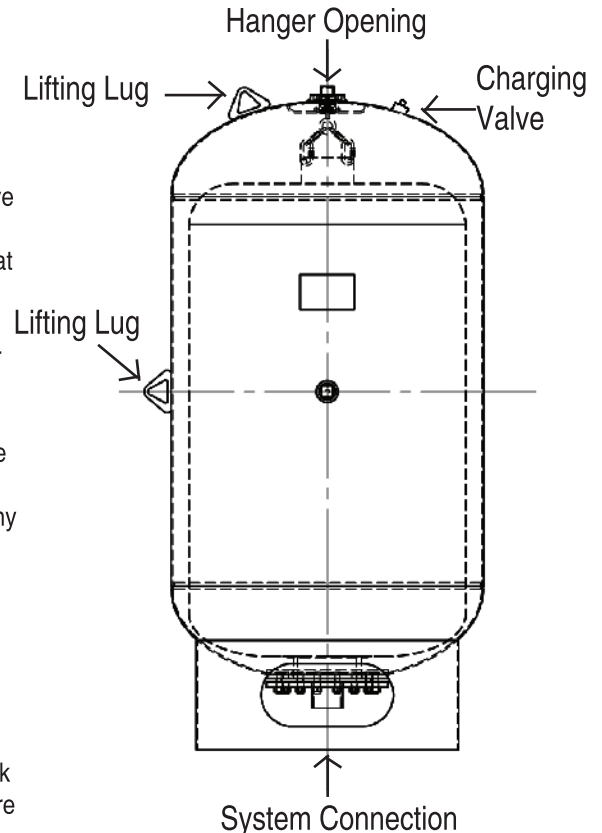

WBF 140 thru WBF 15000

JOB NAME _____
LOCATION _____

CONTRACTOR _____
CONTRACTOR P.O. NO. _____

ITEMS	QUANTITY
_____	_____
_____	_____
_____	_____
_____	_____
_____	_____